

BACK INSIDE.

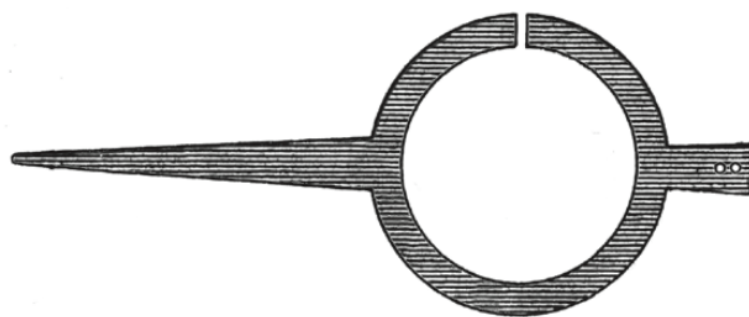

**My fingertips tapped the puddled tiles and the
second hand on my Casio watch ticked steadily on.**

I - Poem: *Round and Round*

II - Poem: *Locking*

III - Epilogue: *Syringes Plunge into Valiant Arms*

for chamber orchestra

Flute (dbl. picc.)

Clarinet in B_♭, (dbl. bass clarinet)

Oboe (dbl. cor anglais)

Bassoon (dbl. contrabassoon)

Horn in F

Trumpet in B_♭

Trombone

Tuba

Perc 1: vibraphone 1, wood blocks, bass drum (shared with perc. 2)

Perc 2: vibraphone 2, sizzle cymbal, bass drum (shared with perc. 1)

Violin

Viola

Violoncello

Double bass

Commissioned, with thanks, by the Philharmonia Orchestra.

Responding to poetry by Tim Key, from his anthology Here We Go Round the Mulberry Bush.

Duration: c. 10'

Arthur Keegan

14.04.23

Programme Note:

Back Inside ... the second hand on my Casio watch ticked steadily on

I – Poem: *Round and Round*

II – Poem: *Locking*

III - Epilogue: *Syringes Plunge into Valiant Arms*

Back Inside responds to an anthology of poems and stories written by Tim Key during lockdown. These poems use witty, absurdist, off-beat imagery to conjure up the uncanny atmosphere of that time. They resonate with my own memories and provide fantastic material for a musical response.

The first movement 'Round and Round' features a prominent line for solo cello which veers from rhythmic, impassioned declamations to softer, freer lines moving within ensemble textures. The harmonic world circles, unchanging, sometimes very slowly, sometimes extremely fast.

The second movement 'Locking' is a song without words. The poem is 'set' in a musical line that moves through the ensemble often in a delicate, dream-like haze.

The final movement contrasts an anxious atmosphere with moments of surreal, cautiously hopeful, serenity.

My thanks go to the Philharmonia Orchestra for the commission and Robin O'Neill, Christian Mason and Anna Clyne for their support and thought-provoking advice throughout this process.

The poetry is Printed with kind permission of Tim Key and "Utter" and Press.

Performance Notes:

- All trills are semi-tones unless a note is stated
- The pedal for Vibraphone 1 remains down throughout so a weight can be used to hold it in place.
- The motor for the vibraphones when on is marked "as slow as possible", set the motor speed to the very slowest setting that retains a smooth rotation of the resonator blades.

Mvt. 2 – Poem:

LOCKING.†

Mvt. 1 – Poem:

ROUND AND ROUND.

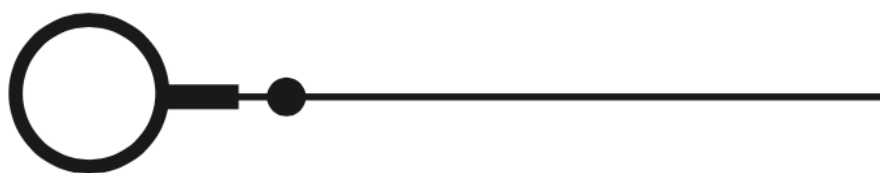

ANOTHER walk.
The same loop.
Eyes closed.
No longer necessary.
Sometimes opening one a tiny
bit to see where I'm going.

AKEY.
Cold, heavy, shoved in a lock.
Its teeth smooth now, ineffective; hunting for grip.
A fist jiggling it.
Panic voices.
The key licking its teeth with its tongue.
Willing its canines to sharpen.
Willing them to find some purchase.
Yearning for the mechanism to clunk open.
Desperate for a release.
Its shaft: ice cold.

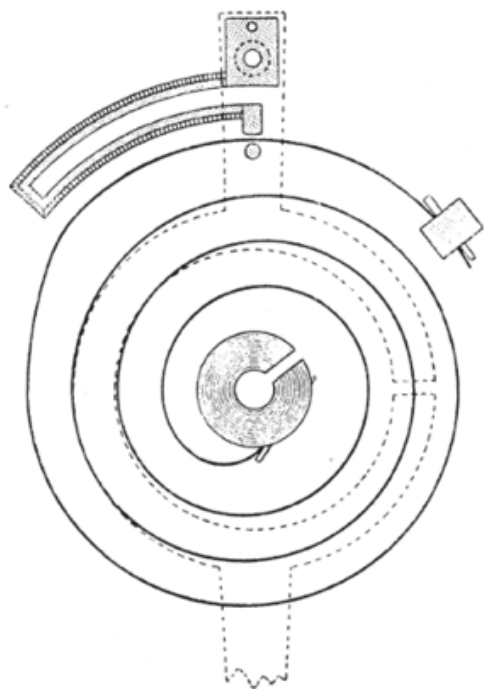

Mvt. 3 – Epilogue:

In which
the syringes start plunging
into valiant limbs,
a hero falls,
and a bubble starts to sparkle.

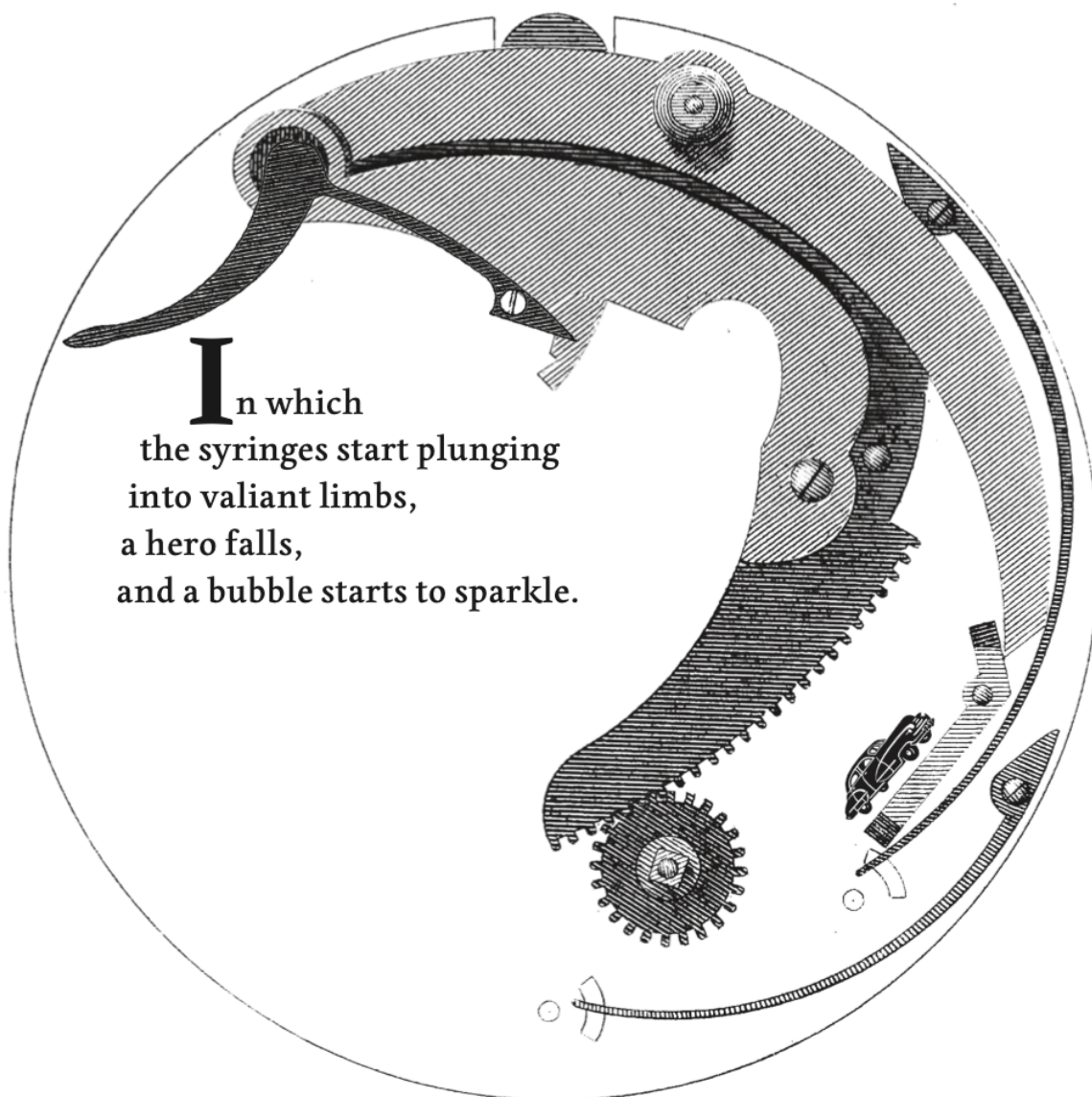

ROUND AND ROUND.

ANOTHER walk.
The same loop.
Eyes closed.
No longer necessary.
Sometimes opening one a tiny
bit to see where I'm going.

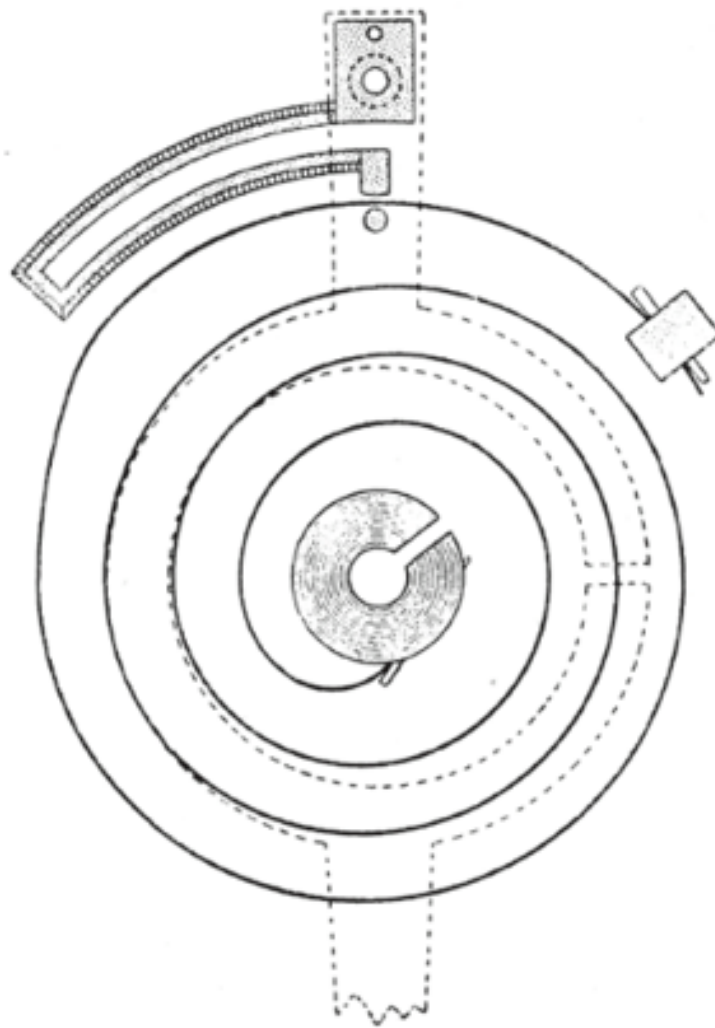

Back Inside

...the second hand on my Casio watch ticked steadily on

I - Poem: Round and Round

Arthur Keegan
poetry by Tim Key

Transposed Score

♩ = 104

The score is for a 4/4 piece in 4/4 time, with a tempo of 104 beats per minute. It is a transposed score. The woodwind section includes Flute, Oboe, Clarinet in Bb, and Bassoon. The brass section includes Horn in F, Trumpet in Bb, Trombone, and Tuba. Percussion includes Wood Blocks (Percussion 1) and Percussion 2. The string section includes Violin, Viola, Violoncello, and Double Bass. The score is divided into six measures. Measures 1-4 are mostly rests for the woodwinds and strings. In measure 5, the Flute, Oboe, Clarinet in Bb, and Bassoon play a short phrase marked *ff*. In measure 6, the Flute and Oboe play a phrase marked *p*, while the Clarinet in Bb and Bassoon play a phrase marked *ff*. The Violoncello has a soloistic part in measure 6, marked *ff* and *pp*. The Wood Blocks play a rhythmic pattern in measure 6, marked *f* and *p*.

9

7 8 10 11 3

Fl. *ff* *pp* *f* *p* *f*

Ob. *ff* *pp* *f* *p* *f*

Cl. *ff* *pp* *f* *p* *f*

Bsn. *ff*

Hn. *mf*

Tpt. *mf*

Tbn. *mf*

Tba.

[Wood Blocks]

Perc. 1

Perc. 2 *p*

Vibraphone motor OFF
bow

Vln. *mp* *poco*

Vla. *mp* *poco*

Vc. *pp* *ff* *mf*

Cb. *p*

Detailed description: This page of a musical score covers measures 7 through 11. The woodwind section (Flute, Oboe, Clarinet, Bassoon) has complex melodic lines with dynamic markings ranging from fortissimo (ff) to pianissimo (pp). The string section (Violin, Viola, Violoncello, Contrabasso) provides harmonic support with various dynamics and articulations. Percussion includes wood blocks and a vibraphone played with a bow. The score is marked with measure numbers 7, 8, 10, 11, and 3. A rehearsal mark '9' is placed above measure 8. Dynamic markings include ff, pp, f, p, mf, and p. Performance instructions like 'Vibraphone motor OFF' and 'bow' are present. The woodwinds feature triplets and slurs. The strings use various bowing techniques and dynamics.

13

This musical score page covers measures 12 through 15. The instruments and their parts are as follows:

- Flute (Fl.):** Measures 12-13 play a melodic line starting with a quintuplet (5) and a dynamic of *p*. Measures 14-15 continue with a more rhythmic pattern, marked *f*.
- Oboe (Ob.):** Measures 12-13 play a triplet (3) with a dynamic of *p*. Measures 14-15 play a rhythmic pattern marked *f*.
- Clarinet (Cl.):** Measures 12-13 play a rhythmic pattern with a dynamic of *p*. Measures 14-15 play a rhythmic pattern marked *f*.
- Bassoon (Bsn.):** Measures 12-13 play a complex line with a triplet (3) and quintuplet (5), marked *mp*. Measures 14-15 play a rhythmic pattern marked *f*.
- Horn (Hn.):** Measures 14-15 play a rhythmic pattern marked *mf*.
- Trumpet (Tpt.):** Measures 14-15 play a rhythmic pattern marked *mf*.
- Trombone (Tbn.):** Measures 14-15 play a rhythmic pattern marked *mf*.
- Tuba (Tba.):** Remains silent throughout.
- Percussion 1 (Perc. 1):** Remains silent throughout.
- Percussion 2 (Perc. 2):** Remains silent throughout.
- Violin (Vln.):** Remains silent throughout.
- Viola (Vla.):** Remains silent throughout.
- Violoncello (Vc.):** Measures 12-13 play a melodic line with a triplet (3) and quintuplet (5), marked *f*. Measures 14-15 play a melodic line marked *fp*, *ff*, and *p*. Measure 15 ends with a dynamic of *ff*.
- Contrabass (Cb.):** Measures 12-13 play a rhythmic pattern. Measures 14-15 play a rhythmic pattern.

17

16 18 19 20 21

Fl. *p* *f* *p*

Ob. *pp* *f* *p*

Cl. *p* *f* *p*

Bsn.

Hn. *pp* *mp* *pp*

Tpt.

Tbn. straight mute *pp* *mp*

Tba. con sord. *pp* *mp*

Perc. 1

Perc. 2

Vln. *p legato* *f* *pp*

Vla. *pp* *poco*

Vc. *mf* *p* *f* *ff* *mp f*

Cb.

Detailed description of the musical score: The score is for measures 16 through 21. It features a woodwind section (Flute, Oboe, Clarinet, Bassoon), brass section (Trumpet, Trombone, Tuba), strings (Violin, Viola, Violoncello, Contrabass), and percussion (Percussion 1 and 2). The woodwinds and strings play melodic lines with various dynamics and articulations. The brass section provides harmonic support with specific mutes and dynamics. The percussion parts are mostly rests. The score includes dynamic markings such as *pp*, *p*, *mp*, *f*, and *ff*, as well as articulations like *legato*, *straight mute*, and *con sord.*. Measure numbers 16, 18, 19, 20, and 21 are indicated at the top.

23

24 25 26 27 28

Fl. *ppp* < *fff* *p* > *ppp* *p* > *ppp* *p* > *ppp* *ppp* *p* > *ppp* *ppp* *p* > *ppp* *ppp* *poco*

Ob. *ppp* < *fff* *ppp* *p* > *ppp* *ppp* *poco* *ppp* *molto legato* *p* *ppp* *poco*

Cl. *ppp* < *fff* *ppp* *p* > *ppp* *pp* *molto legato* *p* *ppp* *poco*

Bsn. *ppp* *molto legato* *p* *ppp* *poco*

Hn. _____

Tpt. _____

Tbn. _____

Tba. _____

Perc. 1 _____

Perc. 2 *pp* *ped down* *l.v. throughout section*

Vln. *ppp* *molto legato* *mp*

Vla. _____

Vc. > *mp* < *f* *mp* *f* *f* *mp*

Cb. _____

30

31

32

Fl. *3 3 3 3 3 3 5 5 5 5*

Ob. *4:3 4:3 4:3*

Cl. *4:3 3 3 3 3 3 3 3*

Bsn. *5 5 5 5*

Hn. *pp f pp*

Tpt.

Tbn. *pp f pp*

Tba. *pp f pp*

[Wood Blocks] *p ff*

[Vibraphone] *3*

Vln. *pp poco 3 3 3 3 3*

Vla. *3 3 3 3*

Vc. *ff molto espressivo pizz*

Cb. *mf*

36

This musical score page covers measures 33 through 37. The instruments and their parts are as follows:

- Flute (Fl.):** Measures 33-34 feature a melodic line with slurs and fingerings (5, 5, 5, 5). Measures 35-37 continue with slurs and fingerings (3, 3, 3, 3, 3).
- Oboe (Ob.):** Measures 33-34 feature a melodic line with slurs and fingerings (3, 3, 3, 3, 3). Measures 35-37 continue with slurs and fingerings (3).
- Clarinet (Cl.):** Measures 33-34 feature a melodic line with slurs. Measures 35-37 feature a melodic line with slurs and 4:3 ratios.
- Bassoon (Bsn.):** Measures 33-34 feature a melodic line with slurs and 4:3 ratios. Measures 35-37 feature a melodic line with slurs and fingerings (5, 5, 5, 5, 5).
- Horn (Hn.):** Measures 33-34 are silent. Measures 35-37 feature a melodic line with slurs and dynamics *pp*.
- Trumpet (Tpt.):** Measures 33-34 are silent. Measures 35-37 are silent.
- Trombone (Tbn.):** Measures 33-34 are silent. Measures 35-37 feature a melodic line with slurs and dynamics *pp*.
- Tuba (Tba.):** Measures 33-34 are silent. Measures 35-37 feature a melodic line with slurs and dynamics *pp*.
- Percussion 1 (Perc. 1):** Labeled "[Wood Blocks]". Measures 33-34 are silent. Measures 35-37 feature a rhythmic pattern with dynamics *p* and *f*.
- Percussion 2 (Perc. 2):** Labeled "[Vibraphone]". Measures 33-34 feature a melodic line with slurs and fingerings (3). Measures 35-37 feature a melodic line with slurs and fingerings (3).
- Violin (Vln.):** Measures 33-34 feature a melodic line with slurs and fingerings (5, 5). Measures 35-37 feature a melodic line with slurs and fingerings (3, 3).
- Viola (Vla.):** Measures 33-34 feature a melodic line with slurs and fingerings (3, 3). Measures 35-37 feature a melodic line with slurs and fingerings (3).
- Violoncello (Vc.):** Measures 33-34 feature a melodic line with slurs. Measures 35-37 feature a melodic line with slurs and dynamics *ff* and *pp*.
- Contra Bass (Cb.):** Measures 33-34 are silent. Measures 35-37 are silent.

38 39 41

Fl. *f* *pp*

Ob. *f* *pp*

Cl. *f* *pp*

Bsn. *f* *pp*

Hn. *f* *pp*

Tpt. *mf* (harmon mute stem out)

Tbn. *f* *pp*

Tba. *f* *pp*

Perc. 1 [Wood Blocks] *p*

Perc. 2 [Vibraphone]

Vln. *mf*

Vla. *mf*

Vc. *ff* molto espressivo
pizz

Cb. *mf* *mf* (as possible)

42 43 44 45

Fl. *5* *5*

Ob. *3* *3* *4:3* *4:3* *4:3*

Cl. *5* *5* *5* *3* *4:3*

Bsn. *4:3* *4:3* *4:3* *5* *5*

Hn. *pp* *f* *pp*

Tpt. *mp*

Tbn. *pp* *f* *pp*

Tba. *pp* *f* *pp*

Perc. 1 [Wood Blocks] *p* *f* *p* *3* *3*

Perc. 2 [Vibraphone] *3*

Vln. *mp* *pp* *poco* *3* *3* *3* *3*

Vla. *3* *3* *3* *3* *3* *3*

Vc. *pp* *ff* *arco* *sfz*

Cb. *mp*

47

Musical score for measures 46-49, featuring woodwinds, brass, strings, and percussion. The score includes parts for Flute (Fl.), Oboe (Ob.), Clarinet (Cl.), Bassoon (Bsn.), Horn (Hn.), Trumpet (Tpt.), Trombone (Tbn.), Tuba (Tba.), Percussion 1 (Perc. 1), Percussion 2 (Perc. 2, including Vibraphone), Violin (Vln.), Viola (Vla.), Violoncello (Vc.), and Contrabass (Cb.).

Measures 46-49 are marked with measure numbers 46, 47, 48, and 49. The score includes various musical notations such as triplets, slurs, and dynamic markings (pp, mp, f).

Key features of the score include:

- Flute (Fl.):** Features a melodic line with triplets and a dynamic marking of *mp* at the end of measure 49.
- Oboe (Ob.):** Features a melodic line with triplets and a dynamic marking of *pp* at the start of measure 47.
- Clarinet (Cl.):** Features a melodic line with triplets and a dynamic marking of *pp* at the start of measure 47.
- Bassoon (Bsn.):** Features a melodic line with triplets and a dynamic marking of *pp* at the start of measure 47.
- Horn (Hn.):** Features a melodic line with a dynamic marking of *pp* at the start of measure 47 and *f* at the end of measure 49.
- Trumpet (Tpt.):** Features a melodic line with a dynamic marking of *pp* at the start of measure 47.
- Trombone (Tbn.):** Features a melodic line with a dynamic marking of *pp* at the start of measure 47 and *f* at the end of measure 49.
- Tuba (Tba.):** Features a melodic line with a dynamic marking of *pp* at the start of measure 47 and *f* at the end of measure 49.
- Percussion 1 (Perc. 1):** Features a melodic line with a dynamic marking of *f* at the end of measure 49.
- Percussion 2 (Perc. 2):** Features a melodic line with triplets and a dynamic marking of *pp* at the start of measure 47.
- Violin (Vln.):** Features a melodic line with triplets and a dynamic marking of *pp* at the end of measure 49.
- Viola (Vla.):** Features a melodic line with a dynamic marking of *pp* at the start of measure 47 and *f* at the end of measure 49.
- Violoncello (Vc.):** Features a melodic line with a dynamic marking of *pp* at the start of measure 47.
- Contrabass (Cb.):** Features a melodic line with a dynamic marking of *pp* at the start of measure 47.

50

This musical score page covers measures 50 through 54. The instruments and their parts are as follows:

- Flute (Fl.):** Measures 50-51: *pp*. Measures 52-53: *f* (4:3), *pp* (4:3). Measure 54: *f* (4:3), *pp* (4:3).
- Oboe (Ob.):** Measures 50-51: *f* (3), *pp* (3). Measure 52: *f* (3), *pp* (3). Measure 53: *pp* (3), *f* (3). Measure 54: *f* (3).
- Clarinet (Cl.):** Measures 50-51: *f* (5), *pp* (5). Measure 52: *f* (3), *pp* (3). Measure 53: *f* (3), *pp* (3). Measure 54: *f* (3), *pp* (3), *f* (3).
- Bassoon (Bsn.):** Measures 50-51: *pp* (4:3), *f* (4:3). Measure 52: *pp* (4:3), *f* (4:3). Measure 53: *pp* (4:3), *f* (4:3). Measure 54: *f* (4:3), *pp* (4:3).
- Horn (Hn.):** Measure 50: *pp*. Measures 51-54: Rest.
- Trumpet (Tpt.):** Measures 50-54: Rest.
- Trombone (Tbn.):** Measure 50: *pp*. Measures 51-54: Rest.
- Tuba (Tba.):** Measure 50: *pp*. Measures 51-54: Rest.
- Percussion 1 (Perc. 1):** Labeled "[Wood Blocks]". Measures 50-51: *pp*, *f* (3). Measure 52: *pp*, *f* (3). Measure 53: *pp*, *f* (3), *pp* (3). Measure 54: *f* (3).
- Percussion 2 (Perc. 2):** Measures 50-54: Rest.
- Violin (Vln.):** Measures 50-51: *f* (3), *pp* (3). Measure 52: *f* (3), *pp* (3). Measure 53: *f* (3), *pp* (3). Measure 54: *f* (3), *pp* (3).
- Viola (Vla.):** Measures 50-51: *f* (3), *pp* (3). Measure 52: *f* (3), *pp* (3). Measure 53: *f* (3), *pp* (3). Measure 54: *f* (3), *pp* (3).
- Violoncello (Vc.):** Measures 50-51: Rest. Measure 52: *f* (3), *pp* (3). Measure 53: *f* (3), *pp* (3). Measure 54: *f* (3), *p* (3), *f* (3), *p* (3).
- Contrabass (Cb.):** Measures 50-54: Rest.

55 56 58 59

Fl. *f pp f pp f*

Ob. *pp f pp mf*

Cl. *pp f pp*

Bsn. *4:3*

Hn. *fff*
harmon mute stem in

Tpt. *fff*
harmon mute stem in

Tbn. *fff*

Tba.

Perc. 1 [Wood Blocks] *pp f*

Perc. 2 *f*
Bass Drum
very dry, crisp

Vln.

Vla.

Vc. *ff p p fff*
3 3 5 6

Cb.

60 **61** 62 63 64 65 66 67

Fl. *p* *ff* *p* *fff* *f*

Ob. *p* *ff* *p* *fff* *f*

Cl. *p* *fff* *f*

Bsn. *fff* *p*

Hn.

Tpt. bells up! senza sord. *fff* bells up! senza sord.

Tbn. *fff*

Tba.

Perc. 1 [Wood Blocks]

Perc. 2 [Bass Drum] *< fff*

Vln. *ff*

Vla. *ff*

Vc. *pp* *f* *pp* *pp* *f*

Cb. *ff*

77

75 76 78 79 80 81 Piccolo

Fl. *p*

Ob. *p* *f*

B. Cl. *p* *f* *p* *p* *f* *p*

Cbsn. *p* *p* *f* *p*

Hn. *p* *f* *p*

Tpt. straight mute *p* *f* *p*

Tbn. straight mute *p* *f* *p*

Tba. *p* *f* *p*

[vibraphone]

Perc. 1 [ped down throughout]

Perc. 2 [vibraphone]

Vln. *f* *pp* *f* *pp* *f* *pp* *f*

Vla. *pp* *f* *pp* *f* *pp*

Vc. *pp* *pp* *f* *pp* *pp* *f*

Cb. *p*

82

86

Flute

83 84 85 87 88

Picc. *f* *ff* *p* *f* *ff* *p*

Ob. *p* *p* *f* *ff* *p* *p*

B. Cl. *p* *f* *ff* *mf* *f* *p*

Cbsn. *p* *f* *ff*

Hn. *mf* *f*

Tpt. [senza sord.] *p* *mf* *f*

Tbn. *p* *mf* *f*

Tba. *mf* *f*

Perc. 1 [vibraphone]

Perc. 2 [vibraphone] *ped off*

Vln. *pp* *p* *f* *fff*

Vla. *f* *pp* *p* *f* *fff*

Vc. *pp* *p* *f* *fff* *f*

Cb. *p* *f* *p* *f* *ff*

90

95

89 91 92 93 94

Fl. *f ma dolce* *p*

Ob. *f ma dolce* *p*

B. Cl. *f* *p* *f ma dolce* *p*

Cbsn. *mf* *p* *f ma dolce* *ff* *p*

Hn. *f ma dolce*

Tpt. *f ma dolce*

Tbn. *f ma dolce* *p* *f* *ff* *p*

Tba. *p* *f* *ff* *p*

Perc. 1

Perc. 2

Vln. *pp* *f*

Vla. *pp* *f*

Vc. *p* *ff*

Cb. *pp* *f*

96 97 98 99 100 102 103

Fl. *p* *mf* *p* *f* *ppp* *mp pp* *mp pp* *mp pp*

Ob. *p* *f* *ppp* *mp pp* *mp pp* *mp pp*

B. Cl. *p* *f* *p* *mp pp* *mp pp* *mp pp*

Cbsn. *mp pp* *mp pp* *mp pp*

Hn. *p pp* *p pp* *p pp*

Tpt. *p pp* *p pp* *p pp*

Tbn. *p pp* *p pp* *p pp*

Tba.

Perc. 1 *f*

Perc. 2

Vln. *p* *mf* *pp* *mp pp* *mp pp* *mp pp*

Vla. *p* *mf* *pp* *mp pp* *mp pp* *mp pp*

Vc. *pp*

Cb. *mp pp* *mp pp* *mp pp*

Bassoon

Wood Blocks

♩ = c. 88

104 106 107 108

Fl. *p*

Ob. *f*

B. Cl. *mf*

Bsn. *mp pp* *mf*

Hn. *p pp*

Tpt. *p pp*

Tbn. *p pp*

Tba.

Perc. 1

Perc. 2

Vln. *mp pp*

Vla. *mp pp*

Vc. *f* *poco* *ma dolce* *sim.* *sim.*

Cb. *mp pp*

dance-like, free, lilting
IV III III

109 110 112 3

Piccolo

Fl. *mf* *p* *molto legato* *ppp*

Ob. *mf* *p* *molto legato* *ppp*

B. Cl. *mp* *ppp* *molto legato*

Bsn. *ppp* *molto legato* Contrabassoon

Hn.

Tpt.

Tbn.

Tba.

Perc. 1 *mf* *ped. down* *bow* *Vibraphone motor ON as slow as possible*

Perc. 2 *mf* *ped down to end →* *bow* *Vibraphone motor ON as slow as possible*

Vln. *p* *con sord.* *p* *3*

Vla. *p* *con sord.* *p*

Vc. *ff > mf* *p* *pp*

Cb.

114

113 115

Picc. *ppp* molto legato 3 5 3

Ob. *ppp* molto legato 3 3 3

B. Cl. *ppp* 3

Cbsn. *ppp* 3

Hn. *ppp* molto legato 3 3 3

Tpt. harmon mute stem out *mp* molto legato 3 *ppp* 5

Tbn.

Tba. con sord. *ppp* 3

Perc. 1 [vibraphone] *mf* 3 *mf*

Perc. 2 [vibraphone] *mf* 3 *mf*

Vln. *ppp* 5 *p* 5

Vla. *ppp* 5 3

Vc. *ff* *pp* 3 *ff* *pp* *ff* *pp*

Cb. *ppp* 5 5 3

117

accel.

116

118

This musical score page contains the following parts and markings:

- Picc.:** Treble clef, 3/4 time. Measures 116-118. Dynamics: *p* to *ppp*. Includes a slur over measures 117-118 with a 5-measure bracket above it.
- Ob.:** Treble clef, 3/4 time. Measures 116-118. Dynamics: *p* to *ppp*. Includes a slur over measures 117-118 with a 5-measure bracket above it.
- B. Cl.:** Treble clef, 3/4 time. Measures 116-118. Dynamics: *mf* (with "in rilievo" below), *f*, *pp*, *ff*. Includes a slur over measures 117-118 with a 3-measure bracket above it.
- Cbsn.:** Bass clef, 3/4 time. Measures 116-118. Dynamics: *mf* (with "in rilievo" below), *f*, *pp*, *ff*. Includes a slur over measures 117-118 with a 3-measure bracket above it.
- Hn.:** Treble clef, 3/4 time. Measures 116-118. Rested.
- Tpt.:** Treble clef, 3/4 time. Measures 116-118. Dynamics: *p* (with "molto legato" below), *ppp*. Includes a slur over measures 117-118 with a 5-measure bracket above it.
- Tbn.:** Bass clef, 3/4 time. Measures 116-118. Rested.
- Tba.:** Bass clef, 3/4 time. Measures 116-118. Includes a slur over measures 117-118 with a 3-measure bracket above it.
- Perc. 1 [vibraphone]:** Treble clef, 3/4 time. Measures 116-118. Dynamics: *mf*. Includes a slur over measures 117-118.
- Perc. 2 [vibraphone]:** Treble clef, 3/4 time. Measures 116-118. Dynamics: *mf*. Includes a slur over measures 117-118 with a 3-measure bracket above it.
- Vln.:** Treble clef, 3/4 time. Measures 116-118. Dynamics: *ppp*. Includes a slur over measures 117-118 with a 3-measure bracket above it.
- Vla.:** Treble clef, 3/4 time. Measures 116-118. Dynamics: *ppp*. Includes a slur over measures 117-118 with a 3-measure bracket above it.
- Vc.:** Bass clef, 3/4 time. Measures 116-118. Dynamics: *ff*, *pp*, *ff*, *pp*, *ff*, *pp*. Includes a slur over measures 117-118 with a 3-measure bracket above it.
- Cb.:** Bass clef, 3/4 time. Measures 116-118. Rested.

♩ = c. 104 (tempo 1)

119 121 122 123

Picc. *f* *p* *ff* *p*

Ob. *f* *p* *ff* *p*

B. Cl. *ppp* *p* *ff* *p* *ff*

Cbsn. *ppp* *p* *ff* *p* *ff*

Hn. *p* *f*

Tpt. senza sord. *p* *f*

Tbn. *p* *f*

Tba. senza sord. *p* *f*

Perc. 1 Wood Blocks *f*

Perc. 2

Vln. *f* *p* *ff* *f* pizz

Vla. *f* *p* *ff* *f* pizz

Vc. *pp* *f* *fff* *p* *ff* *ff*

Cb. *p* *ff*

LOCKING.†



A KEY.

Cold, heavy, shoved in a lock.

Its teeth smooth now, ineffective; hunting for grip.

A fist jiggling it.

Panicked voices.

The key licking its teeth with its tongue.

Willing its canines to sharpen.

Willing them to find some purchase.

Yearning for the mechanism to clunk open.

Desperate for a release.

Its shaft: ice cold.

II - Poem: Locking

♩ = c. 63

fluid, dream-like, delicate

Transposed Score

The score is for a woodwind ensemble and strings. The woodwinds (Flute, Cor Anglais, Clarinet in Bb, Bassoon) have melodic lines with various dynamics and articulations. The strings (Violin, Viola, Violoncello, Double Bass) provide a harmonic accompaniment with sustained notes and dynamic markings. Percussion 2 includes a Sizzle Cymbal and bow.

Flute: Measures 1-5. Dynamics: *ppp*, *p*, *ppp*, *pp*, *ppp*, *p*, *p*. Articulations: *espress*, *poco*. Fingerings: 1, 2, 3, 4, 5.

Cor Anglais: Measures 1-5. Dynamics: *pp*, *ppp*, *p*. Articulations: *poco*. Fingerings: 3.

Clarinet in Bb: Measures 1-5. Dynamics: *p*, *ppp*, *p*, *ppp*. Articulations: *poco*. Fingerings: 5.

Bassoon: Measures 1-5. Dynamics: *pp*, *ppp*, *p*, *ppp*. Articulations: *poco*. Fingerings: 5.

Horn in F: Measures 1-5. Dynamics: *ppp*.

Trumpet in Bb: Measures 1-5. Dynamics: *ppp*.

Trombone: Measures 1-5. Dynamics: *ppp*.

Tuba: Measures 1-5. Dynamics: *ppp*.

Percussion 1: Measures 1-5. Dynamics: *ppp*.

Percussion 2: Measures 1-5. Dynamics: *p*. Articulations: *poco*. Includes Sizzle Cymbal and bow.

Violin: Measures 1-5. Dynamics: *ppp*. Articulations: *poco*.

Viola: Measures 1-5. Dynamics: *ppp*. Articulations: *poco*.

Violoncello: Measures 1-5. Dynamics: *ppp*.

Double Bass: Measures 1-5. Dynamics: *ppp*.

6 7 8 10

Fl. *mf* *ppp* *f* *pp* *mp* *ppp*

C. A. *p* *poco* *p* *ppp*

Cl. *mf* *ppp* *f* *pp* *p* *poco* *mp* *ppp*

Bsn. *mf* *ppp* *f* *pp* *f* *ma dolce* *p*

Hn. *mf*

Tpt.

Tbn.

Tba.

Perc. 1

Perc. 2

Vln. *p* *p*

Vla. *p* *f* *fp* *mf* *f* *ma dolce* *p*

Vc. *f* *fp* *mf* *p*

Cb. *p*

11 12 13 14 16

Fl. *ppp* *mp* *ppp mp* *f*

C. A. *p* *f* *p* *p* *f* *fp*

Cl. *mp* *f*

Bsn. *f* *mp* *f* *ppp* *mp*

Hn. *mp* *p* warm *p*

Tpt. harmon mute stem in *mp* *p* warm

Tbn. harmon mute stem in *mp* *p* warm

Tba. con sord. *p* warm

Vibraphone motor OFF bow Wood Blocks

Perc. 1 *p* *p* *pp* *mp* *f* *mp* *ppp*

Perc. 2 *p* *p*

Vln. *pp* *mp* *p* *f* *ppp*

Vla. *f* *p* *f* *p* *p* *f* *ppp*

Vc. *pp* *mp* *p* *f* *ppp*

Cb. *pp* *mp* *p* *ppp*

This page of a musical score covers measures 17 through 20. The score is arranged in a system with multiple staves for different instruments. The woodwind section includes Flute (Fl.), Clarinet in A (C. A.), Clarinet (Cl.), Bassoon (Bsn.), Horn (Hn.), Trumpet (Tpt.), Trombone (Tbn.), and Tuba (Tba.). The brass section includes Percussion 1 (Perc. 1) and Percussion 2 (Perc. 2). The string section includes Violin (Vln.), Viola (Vla.), Violoncello (Vc.), and Contrabass (Cb.).

Measure 17: Flute (Fl.) starts with a dynamic of *f* and a five-measure rest, then *ppp*. Clarinet in A (C. A.) starts with *fp*. Clarinet (Cl.) starts with *f* and a five-measure rest, then *ppp*. Bassoon (Bsn.) starts with *f* and a five-measure rest, then *ppp*. Horn (Hn.) starts with *mf*. Trumpet (Tpt.) starts with *ppp*. Trombone (Tbn.) starts with *ppp*. Tuba (Tba.) starts with *ppp*. Percussion 1 and Percussion 2 are silent.

Measure 18: Flute (Fl.) has a dynamic of *pp* and a three-measure rest, then *mp*. Clarinet in A (C. A.) has a dynamic of *f* and a three-measure rest, then *mp*. Clarinet (Cl.) has a dynamic of *pp* and a five-measure rest, then *mp*. Bassoon (Bsn.) is silent. Horn (Hn.) has a dynamic of *ppp* and a *poco* marking. Trumpet (Tpt.) has a dynamic of *ppp* and a *poco* marking. Trombone (Tbn.) has a dynamic of *ppp* and a *poco* marking. Tuba (Tba.) has a dynamic of *ppp* and a *poco* marking. Percussion 1 and Percussion 2 are silent.

Measure 19: Flute (Fl.) has a dynamic of *mf* and a five-measure rest, then *p*. Clarinet in A (C. A.) has a dynamic of *mp* and a five-measure rest, then *ppp*. Clarinet (Cl.) has a dynamic of *mf* and a five-measure rest, then *p*. Bassoon (Bsn.) has a dynamic of *mf* and a five-measure rest, then *p*. Horn (Hn.) is silent. Trumpet (Tpt.) has a dynamic of *f* and a five-measure rest, then *pp*. Trombone (Tbn.) is silent. Tuba (Tba.) is silent. Percussion 1 and Percussion 2 are silent.

Measure 20: Flute (Fl.) is silent. Clarinet in A (C. A.) has a dynamic of *ppp*. Clarinet (Cl.) has a dynamic of *pp*. Bassoon (Bsn.) has a dynamic of *pp*. Horn (Hn.) has a dynamic of *mf* and a five-measure rest, then *p* and *f*. Trumpet (Tpt.) has a dynamic of *pp*. Trombone (Tbn.) is silent. Tuba (Tba.) has a dynamic of *mp*. Percussion 1 and Percussion 2 are silent.

22

27

Piccolo

Fl. *p* *ppp* *p* *p* *mf* *p*

C. A. *mf* *mf*

Cl. *p* *ppp* *p* *p* *mf*

Bsn. *p* *ppp* *p* *p* *f fp*

Hn. *p* *mp* *pp* *ppp*

Tpt. *p* *ppp* *p* *mf* *f* *pp*

Tbn. *mp* *pp* *ppp*

Tba. *ppp* senza sord. *ppp*

Perc. 1

Perc. 2 [vibraphone] *hard mal.* *p bright*

Vln. *ppp* *p* *ppp* *mf*

Vla. *mp* *f* *mf* *mf*

Vc. *ppp* *p* *ppp*

Cb.

harmon mute stem out

srraight mute

3

3

3

3

Flute

Picc.

C. A.

Cl.

Bsn.

Hn.

Tpt.

Tbn.

Tba.

Perc. 1

Perc. 2

Vln.

Vla.

Vc.

Cb.

28 29 30 31 32

mf *fp* *ppp*

pp *p* *p* *f* *p* *p*

pp *p* *f* *mf*

p *mf* *p*

pp *mp*

pp *ppp* *poco*

pp *fp*

ppp *poco*

pp

35

33 34 35 36 37 38

Fl. *pp* *mf* *mp* *f*

C. A. *ppp* *fp* *mf* *mp*

Cl. *pp* *mf* *mf* *mp* *mf*

Bsn. *pp* *f* *pp* *f* *pp* *f* *mp*

Hn. *mp* *f* *mp* *pp*

Tpt. [harmon mute stem out] *p* *mf* *p* *f* *mp* *pp*

Tbn. *p* *f* *mp* *pp*

Tba. *p* *f*

Perc. 1 Wood Blocks *mf* *p*

Perc. 2 Sizzle Cymbal sn sticks *pp*

Vln. *ppp* *mp* *p*

Vla. *mf* *pp* *mp* *p*

Vc. *ppp* *mf* *pp*

Cb.

Fl. *p* *mp* *p* *ppp* *ppp*

C. A. *p* *mp* *p* *ppp* *ppp*

Cl. *f* *p* *ppp* *ppp*

Bsn. *p* *mp* *p* *ppp* *f* *p*

Hn. *ppp* *poco*

Tpt. *p* *3* *p* *mp* *ppp* *ppp* *poco* *ppp*

Tbn. *ppp* *poco* *ppp* *poco*

Tba. *pp* *ppp* *con sord.*

Perc. 1

Perc. 2 *Vibraphone* *bow* *mp* *mp* *mp*

Vln. *espress* *pp* *ppp* *p*

Vla. *espress* *pp* *ppp* *p*

Vc. *f* *mp* *p* *ppp* *p*

Cb. *f* *mp* *p*

46

45

47

48

49

50

51

52

Fl. *p* > *ppp* *ppp* *pp* < *mp* > *ppp*

Ob. *pp* < *mp* > *ppp* *pp* < *mp* > *ppp*

Cl. *p* > *ppp* *pp* < *f* > *ppp* *pp* < *mp* > *ppp*

Bsn. *mf* *pp*

Hn. *mp* > *ppp* *mp* > *pp*

Tpt. *pp* < *mp* > *pp*

Tbn. *p* > *ppp* *mp* > *pp*

Tba. *mp* > *pp*

Perc. 1 Bass Drum *pp* < *mp* > *pp* warm

Perc. 2 [vibraphone] *mp* Sizzle Cymbal bow *mf* l.v.

Vln. *ppp* < *mp* >

Vla. *ppp* < *mp* >

Vc. *pp* < *mp* > *ppp* < *mp* >

Cb. *pp* < *mp* > *ppp*

In which
the syringes start plunging
into valiant limbs,
a hero falls,
and a bubble starts to sparkle.



III - Epilogue: Syringes plunge Into valiant arms

Transposed Score

♩ = c. 96

5

The musical score is arranged in a system of staves. The instruments and their parts are as follows:

- Piccolo:** Treble clef, 4/4 time. Starts with a *pp* dynamic, moving to *mp*. Features a series of triplets (2, 3, 4) and trills. Dynamics include *sfz* and *f*.
- Oboe:** Treble clef, 4/4 time. Starts with a *pp* dynamic, moving to *mp*. Features a series of triplets and trills. Dynamics include *sfz* and *f*.
- Clarinet in Bb:** Treble clef, 4/4 time. Starts with a *pp* dynamic, moving to *mp*. Features a series of triplets and trills. Dynamics include *f* and *mp*.
- Bassoon:** Bass clef, 4/4 time. Remains silent throughout the passage.
- Horn in F:** Treble clef, 4/4 time. Starts with a *f* dynamic. Features a series of triplets. Dynamics include *f* and *mp*.
- Trumpet in Bb:** Treble clef, 4/4 time. Remains silent throughout the passage.
- Trombone:** Bass clef, 4/4 time. Remains silent throughout the passage.
- Tuba:** Bass clef, 4/4 time. Remains silent throughout the passage.
- Percussion 1:** Treble clef, 4/4 time. Remains silent throughout the passage.
- Percussion 2:** Treble clef, 4/4 time. Remains silent throughout the passage.
- Violin:** Treble clef, 4/4 time. Starts with a *fp* dynamic, moving to *ppp*. Features a series of triplets. Dynamics include *pp* and *ppp*.
- Viola:** Treble clef, 4/4 time. Starts with a *fp* dynamic, moving to *ppp*. Features a series of triplets. Dynamics include *ff* and *in rilievo*.
- Violoncello:** Bass clef, 4/4 time. Starts with a *fp* dynamic, moving to *ppp*. Features a series of triplets. Dynamics include *pp* and *ppp*.
- Contrabass:** Bass clef, 4/4 time. Remains silent throughout the passage.

Picc. *6* *mp* *f* *5* *mp* *7* *sfz* *f* *3* *mp* *sfz*

Ob. *5* *f* *mp* *3* *sfz* *f* *mp* *3* *3* *sfz*

Cl. *(tr)* *f* *6* *mp* *5* *f* *3* *mp* *f* *3* *mp* *f* *3* *mp*

Bsn.

Hn.

Tpt.

Tbn.

Tba.

Perc. 1

Perc. 2

Vln. *3* *3* *f*

Vla.

Vc. *3* *f*

Cb. *pp* *3* *3* *3* *3* *f*

11

This musical score page, numbered 39, features a rehearsal mark of 11. It contains staves for the following instruments: Piccolo (Picc.), Oboe (Ob.), Clarinet (Cl.), Bassoon (Bsn.), Horn (Hn.), Trumpet (Tpt.), Trombone (Tbn.), Tuba (Tba.), Percussion 1 (Perc. 1), Percussion 2 (Perc. 2), Violin (Vln.), Viola (Vla.), Violoncello (Vc.), and Contrabass (Cb.). The score is divided into three measures. The first measure (measures 9-10) shows dynamic markings of *f* and *ff* for the Piccolo, and *ff*, *f*, and *ff* for the Oboe, Clarinet, and Bassoon. The second measure (measures 10-11) features dynamics of *f* and *p* across various instruments, with some triplets and sixteenth-note patterns. The third measure (measures 11-12) includes dynamics of *f*, *p*, and *ff*. The Violin and Viola parts are marked *pizz* (pizzicato) with dynamics of *p* and *f*. The Violoncello part includes *pizz* and *arco* (arco) markings. The Contrabass part is marked *pizz* and *f*. The Percussion parts are mostly silent, with Perc. 2 ending with a fermata.

12 13 14 15

Picc. *p* *f* *ppp*

Ob. *f* *ppp*

Cl. *p* *f* *ppp*

Bsn. *f* *ppp*

Hn. *f* *p* *pp* *ff* *p*

Tpt. *p* *pp* *ff* *p*

Tbn. *p* *mf* *pp* *ff* *p*

Tba. *f* *p* *mf* *pp* *ff* *p*

Perc. 1

Vibraphone motor OFF resonators closed
hard mal

Perc. 2 *f* bright

Vln. arco *sfz p* *fff*

Vla. arco *sfz p* *fff*

Vc. arco *p* *f* *fff*

Cb. arco *p* *f* *fff*

molto rit. ♩ = c. 62

molto accel. tempo 1 ♩ = c. 96

20

16 17 18 19 21

Picc. *mf* ³

Ob. *mf* ³

Cl. *ppp*

Bsn.

Hn. *ppp* *pp* *mf* ³

Tpt. *ppp* *pp* *mf* ³

Tbn. *ppp* *pp* *mf* ³

Tba. *ppp* *pp* *mf* ³

Vibraphone motor ON, as slow as possible
soft mal.
[ped down throughout] *pp* warm

Perc. 1

Perc. 2 bow *f* sim.

Vln. *ppp* *ppp*

Vla. *ppp* *ppp* *ppp*

Vc. *ppp* *ppp*

Cb. *ppp*

sempre *tr*

senza vib → slow molto vib → *tr*

27 28 29 30 31

Picc. *p* *ff* *ff*

Ob. *p* *ff* 3

B. Cl. *p* *f* *p subito* *f*

Cbsn. *p* *f* *p subito* *f*

Hn. *pp*

Tpt. *pp*

Tbn. *pp*

Tba. *pp*

Perc. 1 [vibraphone] damp with hand

Perc. 2 [vibraphone]

Vln. *f* pizz *f* pizz

Vla. *f* pizz

Vc. *p* *f* *pp* *f* arco *p subito*

Cb. *p* *f* *pp* *f* pizz arco *p subito*

33

32 34 35

Picc. *f* 3

Ob. *f* 3

B. Cl.

Cbsn.

Hn.

Tpt. *f*

Tbn. *f* 5 *p* 3 *f*

Tba. *f* 3 *p* *f*

Perc. 1 [vibraphone] *mal* in one hand *bow* in other [motor ON] *soft mal.* *mp* *soft, make a wash* *f* *sempre* *bow* *rhythm not strict, avoid strong pulse shape is slowing toward minims in bar 37*

Perc. 2 [vibraphone] *mal* in one hand *bow* in other [motor OFF] *soft mal.* *mp* *soft, make a wash ped. down until end →* *f* *sempre* *bow* *rhythm not strict*

Vln.

Vla.

Vc. *f*

Cb. *f*

37

36 38 39

Picc. *mp* *p*

Ob. *mp* *p*

Cl. *f* *mp* *p*

Cbsn.

Hn.

Tpt.

Tbn.

Tba.

Perc. 1 [vibraphone] [*f*]

[vibraphone]

● roughly = 1st time

repeat ad lib.
gently slow down each repeat ad lib.
uneven, no clear sense of pulse

Vln. *mp* *f* *p* *mf*

Vla. *mp* *f* *p* *mf*

Vc. *mf* *mp* *p* *mf*

Cb. *mf* *mp* *p* *mf*

arco spiccato

arco col legno (half hair)

spiccato

col legno (half hair)

40 41 42 44 45

Picc. *pp* *f* *p* *f* *ff*

Ob. *mf* *f* *f* *ff*

Cl. *pp* *f* *p* *f* *ff*

Cbsn. *p*

Hn. *mp < fp* *p* *f* *ff*

Tpt. *mf* *pp* *mp* *p* *f* *ff*
 harmon mute stem out
 harmon mute stem in

Tbn. *mp < fp* *p* *f* *ff*
 harmon mute stem out
 harmon mute stem in

Tba. *mp < fp* *p* *f*

Perc. 1 [vibraphone] *f*
 rhythm now strict
 stop repeat in this bar
 [sempre forte]
 rhythm now strict
 [sempre forte]

Vln. *pp* *pp* *mf* *f*
 ord.
 spiccato

Vla. *pp* *pp* *mf* *f*
 ord.
 col legno (half hair)

Vc. *f* *f mp*
 spiccato
 ord.

Cb. *f* *f mp*
 spiccato
 ord.

49

46 47 48 50 51

Picc. *pp* *p*

Ob. *pp*

Cl. *tr* *p < ffff* *pp* *p*

Cbsn. *tr* *ffff* *p*

Hn. *tr* *p* *ffff*

Tpt.

Tbn. *growl* *p* *senza sord.* *ffff*

Tba. *p* *ffff*

Perc. 1 [vibraphone] [*f*]

Perc. 2 [vibraphone] [*f*]

Vln. *col legno ric.* *pizz* *mf* *mp* *arco col legno ric.* *pizz* *mf* *mp*

Vla. *pizz* *arco col legno ric.* *mf* *f* *pizz* *arco col legno ric.* *mp* *f*

Vc. *pp* *pizz sul pont. with nail (or plectrum) damp string slightly* *p very dry, bright sound*

Cb. *pp* *pizz sul pont. with nail (or plectrum) damp string slightly* *p very dry, bright sound*

Bassoon

53

52 54 55

Picc. *mf* \triangleright *p*

Ob. *p* *mf* \triangleright *p*

Cl. *mp* *mf* \triangleright *p*

Bsn. *mp* *mf* \triangleright *p*

Hn.

Tpt.

Tbn.

Tba.

Perc. 1 [vibraphone] [*f*]

Perc. 2 [vibraphone] [*f*]

Vln. arco col legno ric. *mf* pizz *mp* arco col legno ric. *mf* pizz *mp*

Vla. pizz *mp* arco col legno ric. *f* pizz *mp* arco col legno ric. *f*

Vc.

Cb.

56 57 58 59 60 61

This musical score page contains the following parts and markings:

- Picc.**: *mp* (measures 56-57), *fp* (measures 58-60)
- Ob.**: *mf* (measures 56-57), *mp* (measure 58), *fp* (measures 59-60)
- Cl.**: *mf* (measures 56-57), *mp* (measure 58), *f* (measure 59), *p* (measure 60)
- Bsn.**: *mp* (measures 56-57)
- Hn.**: Rested throughout
- Tpt.**: Rested throughout
- Tbn.**: Rested throughout
- Tba.**: Rested throughout
- Perc. 1**: [vibraphone], *[f]* (measures 58-60)
- Perc. 2**: [vibraphone], *[f]* (measures 58-60)
- Vln.**: *mf* (measure 56), *ric.* (measures 57-58), *pizz* (measure 58), *arco* (measures 59-60), *fp* (measures 59-60)
- Vla.**: *pizz* (measure 56), *mp* (measures 56-57), *f* (measure 58), *arco* (measures 59-60), *fp* (measures 59-60)
- Vc.**: *arco* (measures 59-60), *fp* (measures 59-60)
- Cb.**: Rested throughout

